

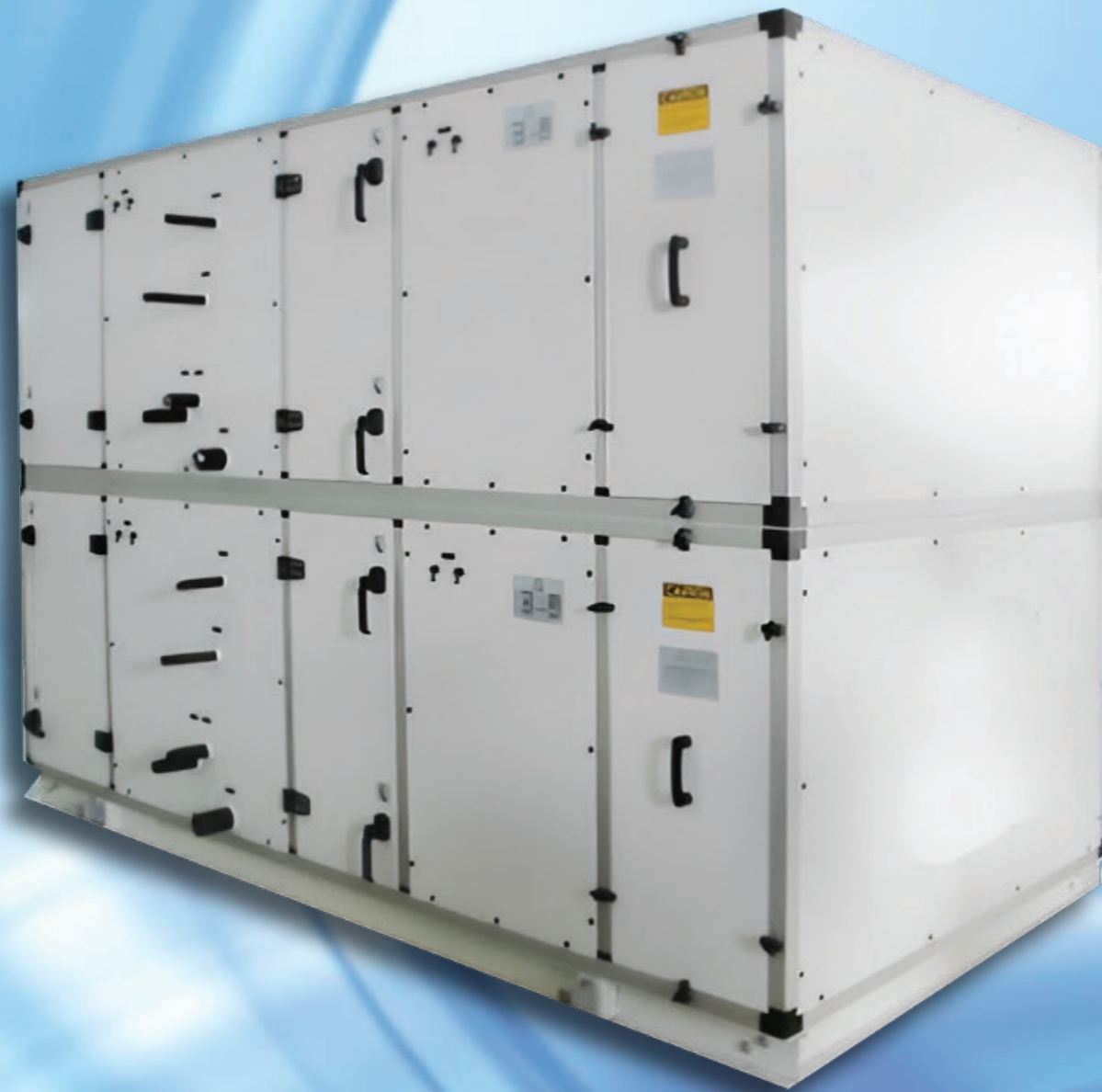

ALTER

Aluminum Frame Design.



Alter Airconditioning Co.,Ltd.

99/5 Moo.20 Lamlukka, Lamlukka, Pathumthani 12150 Thailand.

Tel : +662 023 4172-74 Fax : +662 023 4175

E-mail : sales@alter.co.th Website : <http://www.alter.co.th>

Alter Air conditioning Co.,Ltd. participates in the ECP Programme fro AHU.

Check ongoing validity of certificate. www.eurovent-certification.com





COMPANY PROFILE

GENERAL INFORMATION

The Alter Air Handling Units

are modular in design and is available in both horizontal and vertical con figuration with a variety or discharge arrangement. These units may be arranged to meet almost any space or duct requirements. Each unit comes complete, cooling coil, motor and drive package and it is also available with a choice of accessories such as filter section, mixing box section, face and bypass damper, etc. to meet any air-condition, or filtration needs.



ALTER AIRCONDITIONING COMPANY

was established in 1989 as a sub-contracting company mainly involving in the Construction Heating, Ventilation and Air Conditioning systems / clean rooms / environmental buildings and factories utilities systems. later in 1991 a joint - venture company with a Japanese air handling units in Thailand to serve the local Japanese market only. at the end of 2003, the Thai partners decided to spit out to serve the local market more comprehensively with newer technology from European manufacturers.

ALTER SALES SERVICE

To support all out customers should any problems arise gourine installations, operations and maintenance period at all times.

PRODUCT RANGE

Model ALT40	Module		Max Air Volume (CMH)	Coil Face Area (m ²)	Coil Face Velocity (m/s)
	Height (Module)	Width (Module)			
015-01-02	1.0	2.0	1,500	0.19	2.24
030-02-02	2.0	2.0	3,000	0.37	2.24
045-02-03	2.0	3.0	4,500	0.56	2.24
045-03-02	3.0	2.0	4,500	0.56	2.24
060-02-04	2.0	4.0	6,000	0.74	2.24
060-03-03	3.0	3.0	6,000	0.84	1.99
090-03-04	3.0	4.0	9,000	1.11	2.24
120-04-04	4.0	4.0	12,000	1.49	2.24
150-04-05	4.0	5.0	15,000	1.86	2.24
150-05-04	5.0	4.0	15,000	1.86	2.24
180-04-06	4.0	6.0	18,000	2.23	2.24
180-05-05	5.0	5.0	18,500	2.32	2.15
225-05-06	5.0	6.0	22,000	2.79	2.24
240-04-08	4.0	8.0	24,000	2.97	2.24
270-06-06	6.0	6.0	27,500	3.34	2.24
315-06-07	6.0	7.0	31,500	3.90	2.24
315-07-06	7.0	6.0	31,500	3.90	2.24
360-06-08	6.0	8.0	36,000	4.46	2.24
360-07-07	7.0	7.0	36,000	4.55	2.20

Dimension Calculation

External AHU Height : Module x 305 + 240 + 84 + Base AHU

External AHU Width : Module x 305 + 325 + 84

Example : Model 030-02-02

External AHU Height : 2 x 305 + 240 + 84 + 100 = 1034 mm.

External AHU Width : 2 x 305 + 325 + 84 = 1019 mm.

COMPUTER PROGRAM.



ISO 9001 : 2015



EUROVENT



EUROVENT

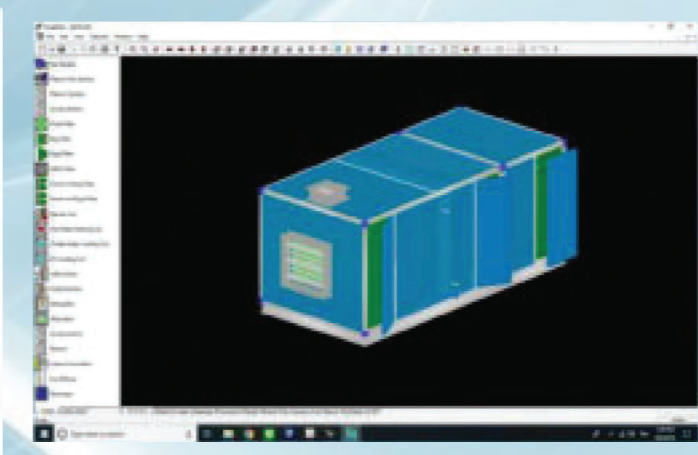

TREATMENT SECTION

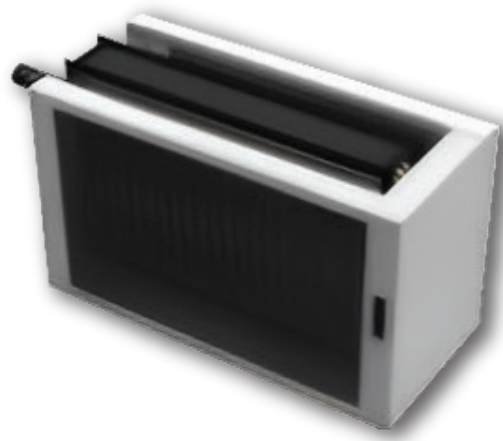

Heat Pipe

Heat pipes may be described as having two sections: pre-cool and reheat. The first section is located in the incoming air stream. When warm air passes over the heat pipes, the refrigerant vaporizes, carrying heat to the second section of heat pipes, placed downstream. Because some heat has been removed from the air before encountering the evaporator coil, the incoming air stream section is called the pre-cool heat pipe.

Hot Gas Reheat

When the compressor is running to reduce room temperature (sensible heat) and humidity (latent heat) respectively, the compressor normally runs beyond the room temperature set point to continue the dehumidifying process. When the night humidity level has been achieved, the system requires reheating to compensate for overcooling. Usually, electric heaters are used.

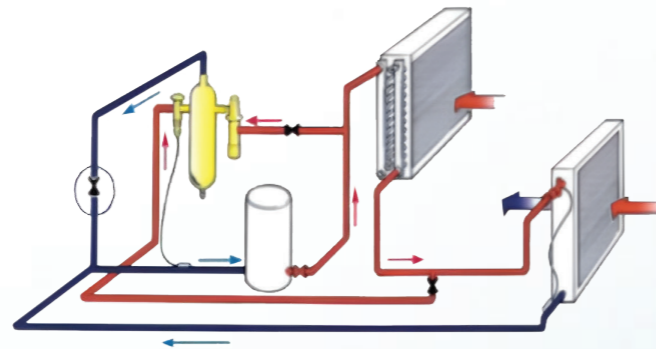

• Eurovent Test Report

Thermal transmittance	T2
Thermal bridging of the casing	TB3
Mechanical strength of casing	D1(M)
Casing air leakage	L1(M) - 400 Pa / >L3(M) +700 Pa
Filter bypass leakage	F9

For addition, please refer to technical data Sheet "Door System of Air Handling Units"

Panel 42 mm

Are constructed of the same material as the fixed panels. The access panel shall be low leak construction with a hex socket compression type latch assembly and large & nonconductive handles for easy removal of the access panel.

-Thermal conductivity (k) = 0.0204 W/m.K (0.0118 Btu/ft.h °F)

-Heat transfer coefficient of panel 42 mm thickness (k/L) = 0.510 W/m².K (0.0898 Btu/ft² h °F)

-Density = 40 kg./m³

Sandwiched between galvanized steel with pre-painted finish and stainless is also available.

DOUBLESKIN PANEL 42 MM

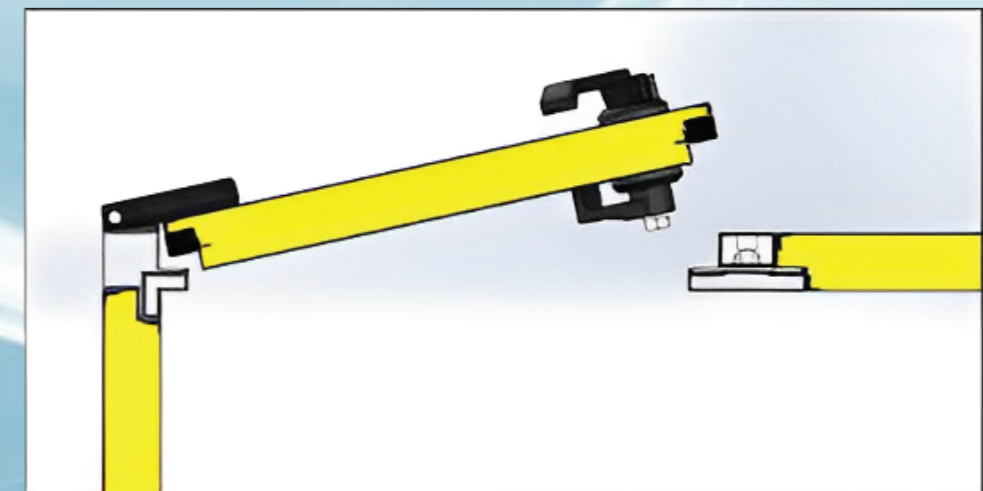
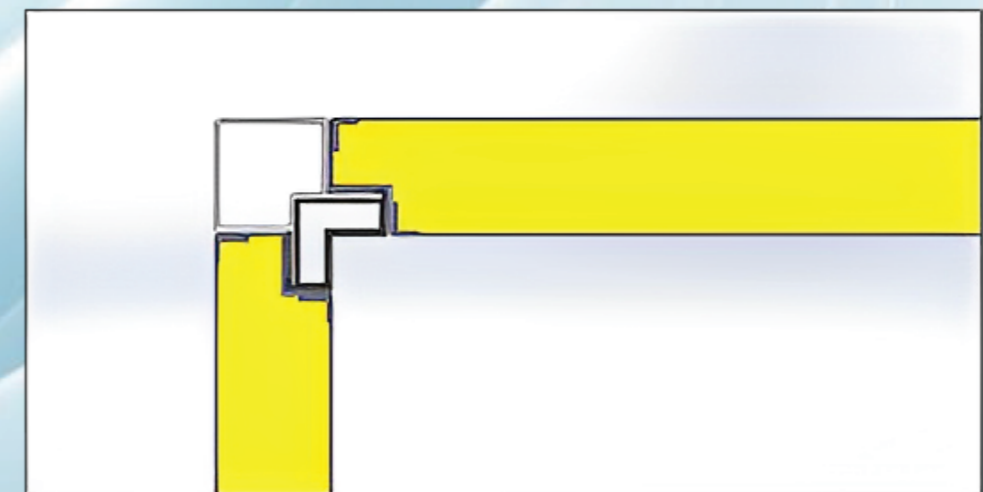



VOLUME DAMPER



WATER PROOF SW.



LAMP



PRESSURE PORT



INSPECTION WINDOW

Filter Section



Fully sealed filter sections are designed for easy withdrawal and renewal of filter cell and, are constructed to house any type of primary or secondary filters of different media with various efficiencies. In Areas of particular importance, such as hospitals and clean rooms, absolute filters can be provided to ensure safe human and machine

Coil Section

Coil are software selected to obtain optimum psychometric efficiency with low air and water pressure drops. Chilled water, Direct Expansion, Hot Water and Steam Coil are constructed from copper tubes, mechanically bonded to aluminum fins as standard. Other fin materials are available including coated aluminum tinned copper. for corrosive flow media, stainless steel tubes and fins are available as an option. The coil assemble completed with carbon steel or copper headers is located within the coil section can be withdrawn from either side.

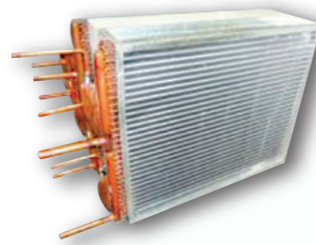

Fan Section

Fan and motor from the heart of all systems. Forward Curved or Backward Plug Fan Curend non overloading Aero Foil Centrifugal fans are available with various outlet configuration. all fan wheels and pulley are individually tested and precision balaaances, statically and dynamically, and Keyed to the shaft. Motor, mounted on slide rails with Provision for easy belt tensoning, drive the fan with heavy duty V-belts. Combination spring and rubber vibration isolators are selected to match the power / weight fan for VAV applications.



Motor

All motors used are 3-phase induction motor Enclosed fan cooled type and the ball bearing are totally sealed which requires no lubrication. Motors are mounted to the blower framer frame on an adjustable base for easy alignment and belt tensoning.

ACCESSORIES

